

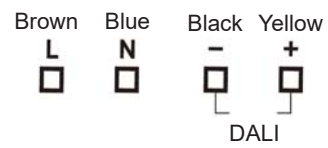

Master Sensor

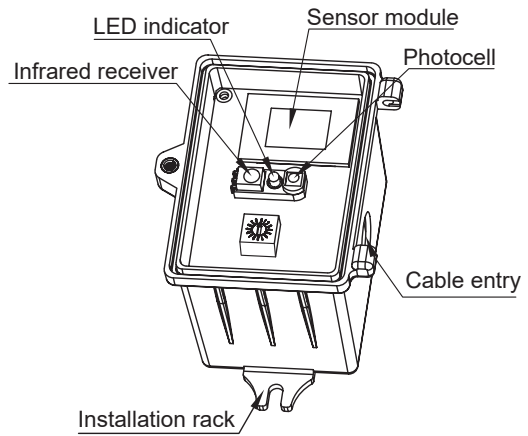
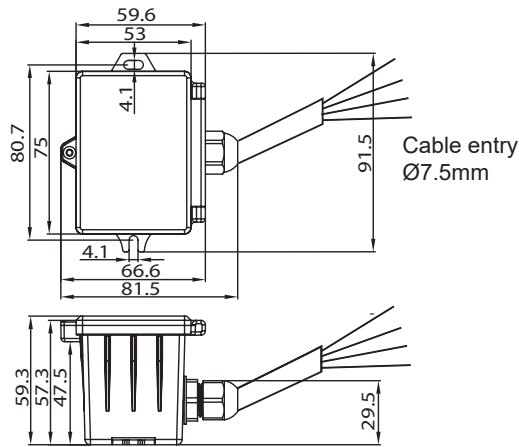

1. Technical Specifications

Product type	RF wireless microwave sensor (tri-level control)
Operating voltage	120-277VAC 50/60Hz
Rated load	Maximum 40mA
Power consumption	< 1.5W
Detection angle	360°
Detection area (DxH)	10 x 12m (Maximum)
Mounting height	12m (Maximum)
Detection range	10% / 50% / 75% / 100%
Hold time	2s / 30s / 1min / 5min / 10min / 15min / 20min / 30min
Daylight threshold	2 - 500Lux, Disable
RF transmission distance	30 metres in an open area
RF frequency	868MHz (FSK mode)
Warming up time	20s
Operating temperature	-20°C - +50°C
IP rating	IP65

Detection Pattern

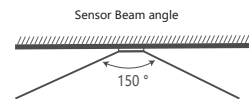

Wall Detection

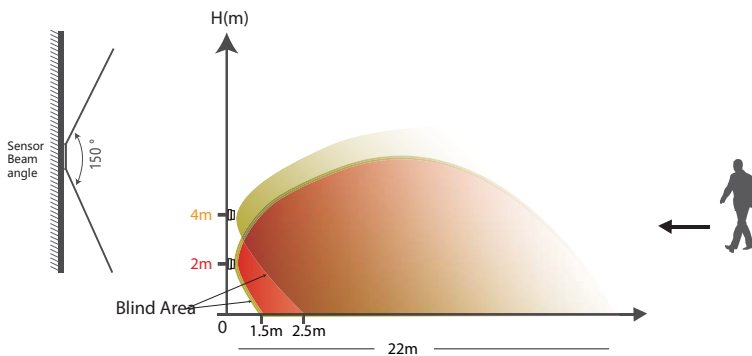

Ceiling mounted detection pattern

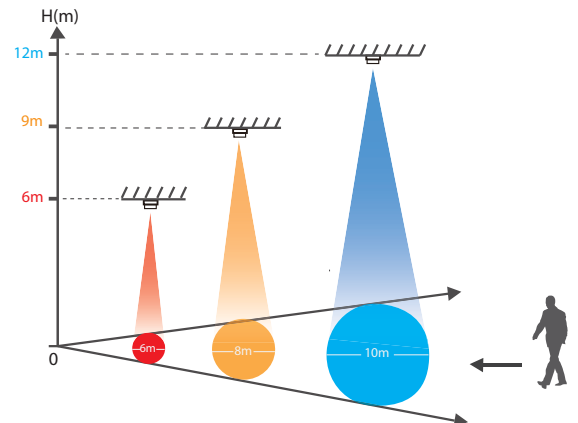

NOTE: The actual detection area can be different, depending on the object size, speed and etc.

2. Installation

⚠ Warnings:

1. Installation must be carried out by a qualified engineer in accordance with local regulations.
2. Disconnect supply before installing.
3. Install to a solid surface - vibrations may cause mis-triggering.
4. Ensure environmental conditions are suitable for electronic equipment

Lux Off Function

The built-in daylight sensor can read ambient natural light and switch off the luminaire(s) automatically whenever artificial light is not required (natural light level exceeds daylight threshold).

Note: if the stand-by time is preset at "+∞", the luminaire(s) never switch off even when natural light is sufficient.

NOTE: install the sensor first!

The master sensor must first be installed in the system, as the RFX version FLEXPAK luminaires do not function without the master sensor.

The master sensor contains the memory and configuration settings for the luminaires. If the luminaires are installed without the master sensor, they will switch on as no sensor was detected during the self-calibration test. It is possible to manually turn off individual luminaires with the remote control, however as there is no memory storage in the luminaire (node), manually turning off the luminaires with the remote control will not be remembered if the master-sensor is not connected and the supply power to the luminaire is switched on.

3. Step grouping



Bring all luminaires that should be grouped in learn mode by short press on "Learn/Erase". Point IR remote control to the intelligent eye in the centre of the luminaire.

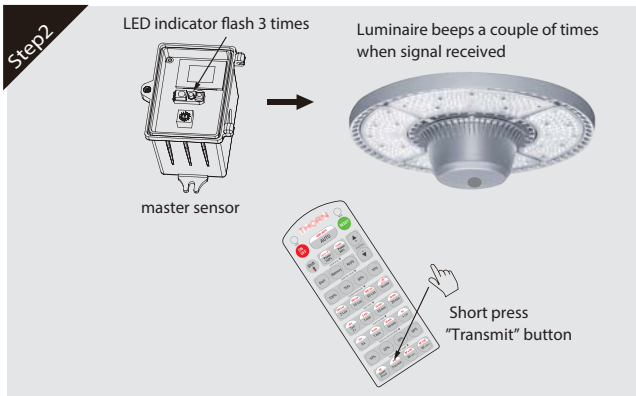

Press "Transmit" towards all sensors that should be paired with the luminaires in learn mode. The sensor will blink 3 times and the luminaire will beep a couple of times.



Stop learn mode of each luminaire by pressing "Learn/Erase" again while pointing to the "intelligent eye". Grouping is finished now.

4. Settings

Permanent ON/OFF [button ①]

Press button ①, to select permanent ON or permanent OFF mode.
* Press button ② / ④ to resume automatic operation.

RESET [button ②]

Press button ② , all settings go back to the default settings.

Shift [button ③]

Press button ③ , the LED on the top left corner will flash to indicate mode selection.

All values / settings in RED are active for 20 seconds.

Auto Mode [button ④]

Press button ④ to initiate automatic mode. The sensor starts working and all settings remain as before the light was switched ON/OFF.

Note: the function of semi-auto is disabled.

Scene prog. [zone ⑦] (One-key-commissioning)

- 1) Press button "Start" to program
- 2) Select the button in "Detection range" ⑧; "Daylight threshold" ⑨ and the "hold time" ⑩ to define all the parameters.
- 3) Press button "memory" to save all those programmed settings in the remote control.
- 4) Press the button "Apply" and point the RC to the sensor to apply the "Detection range and daylight threshold"
- 5) Press the button "Apply" and point to the "node" ,which will be behind the "Intelligent eye".

*If you press the button "Apply" you will get a flashlight from the sensor

Detection range [zone ⑧]

Define different detection range for need of longer/shorter. detection range.

Press buttons in zone ⑧ to set detection range at 100% / 75% / 50% / 10%.

*pls note: point to the sensor.

Daylight threshold [zone ⑨]

Define different daylight threshold fit for particular application. Press buttons in zone ⑨ to set the daylight sensor at 2Lux / 10Lux / 50Lux / 100Lux / 300Lux / 500Lux or Disable.

Note: To set daylight sensor at 100Lux / 300 Lux / 500Lux, press button ③ Shift at first.

*pls note: point to the sensor.

Ambient daylight threshold [button ⑩]

Enable the daylight sensor to be commissioned to the environment in which unit installed.

1. Press button ③ Shift, the red LED is on for indication.
2. Press button ⑩, the ambient lux level is sampled and set as the new daylight threshold.

*pls note: point to the sensor.

Hold time [zone ⑪]

Define the time period to keep the luminaire on 100% after the person left the detection area.

Press buttons in zone ⑪ to set the hold time at 2s / 30s / 1min / 5min / 10min / 15min / 20min / 30min.

Note: 1. To set hold-time at 30s / 5min / 15min / 30min, press button ③ Shift at first.

2. 2s is for test purpose only, stand-by period and daylight sensor settings are disabled in this mode.

*To exit from Test mode, press button ② or any button in zone ⑪ .

*pls note: point to the sensor to the FLEXPAK/NODE.

Stand-by time [zone ⑫]

Not supported

Stand-by dimming level [zone ⑬]

Not supported

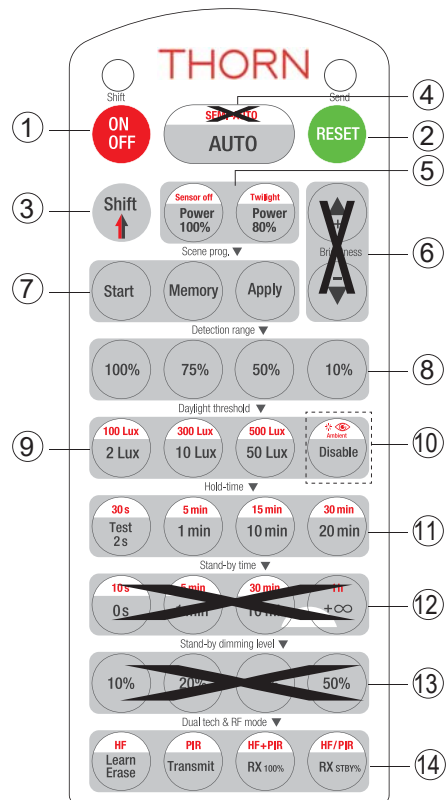

5. Trouble Shooting

MALFUNCTION	CAUSE	REMEDY
The luminaire does not light up	Incorrect daylight threshold setting	Adjust daylight threshold setting
	No power supply	Check power to sensor
	Detection zone not targeted	Check detection area setting
The luminaire is always on	Continued movement in the detection zone or the luminaire is not grouped to a sensor	Check detection area setting
The luminaire is on when it should not be	Sudden change in temperature due to weather (wind, rain, snow) or air expelled from fans, open windows	Adjust zone, change installation site
Sensor does not work	Sensor is defective	Order a new sensor. Meanwhile use the remote control to control the FLEXPAK directly or switch on the main power -since the initial setting always turns the luminaire on

6. Appendix

Detection range (add the graph)

